

CHOCOLATE CASE

SCD-1500D

≡ FEATURES / BENEFITS ≡

▪ EXCEPTIONAL EXTERIOR AND SURFACE

It is designed with exceptional exterior and surface and demand of all users is matched. The glass is superclear and it can display properly.

▪ DIGITAL CONTROL SYSTEM

Easy settings of operating mode, temperature and humidity.

▪ HIGH-DENSITY POLYURETHANE INSULATION

The entire cabinet structure are foamed-in-place using high density, CFC free polyurethane insulation.

▪ EFFICIENT REFRIGERATION SYSTEM

SKIPIO's refrigerators are designed with oversized and balanced (CFC Free R-134A) refrigeration systems. These include efficient evaporators and condensers for faster cooling and greater efficiency.

▪ EFFICIENT REFRIGERATION SYSTEM

SKIPIO's refrigerators are designed with oversized and balanced refrigeration systems. These include efficient evaporators and condensers for faster cooling and greater efficiency.

▪ FORCED AIR COOLING SYSTEM

Fast cooling and balanced temperature throughout the cabinet.

▪ AIR FLOW GRILLE

Smooth air flow to maintain a consistent temperature, which is required for delicate food items. Fitted with LED lights to showcase your food products for high visibility.

▪ LED INTERIOR LIGHTING BLOW

Bright LED interior lighting is specifically designed blow for perfect visibility.



▪ ADD : 218 WOODPARK ROAD SMITHFIELD NSW 2164
▪ TEL : 02 - 8798 - 5061 / 5283 / 5581
▪ FAX : 02 - 8798 - 5707

CHOCOLATE CASE

SCD-1500D

MODEL : SCD-1500D

PLAN VIEW

SPEC SHEET	SCD-1500D
Cabinet Dimension(W*D*Hmm)	1500 * 800 * 930
Capacity(L)	130
Inner Temperature(°C)	Bakery 0~5 Chocolate 10~14 (Humidity 50±5%)
Ambient Temperature(°C)	35
Refrigerant	R-134a
Insulation Type	Polyurethane / cyclopentane + CFC Free
Amps(A)	3
Voltage (V/Hz/PH)	240 / 50 / 1
Weight	240
# of drawers	2
# of doors	4
Compressor	1/3
Power plug	10A

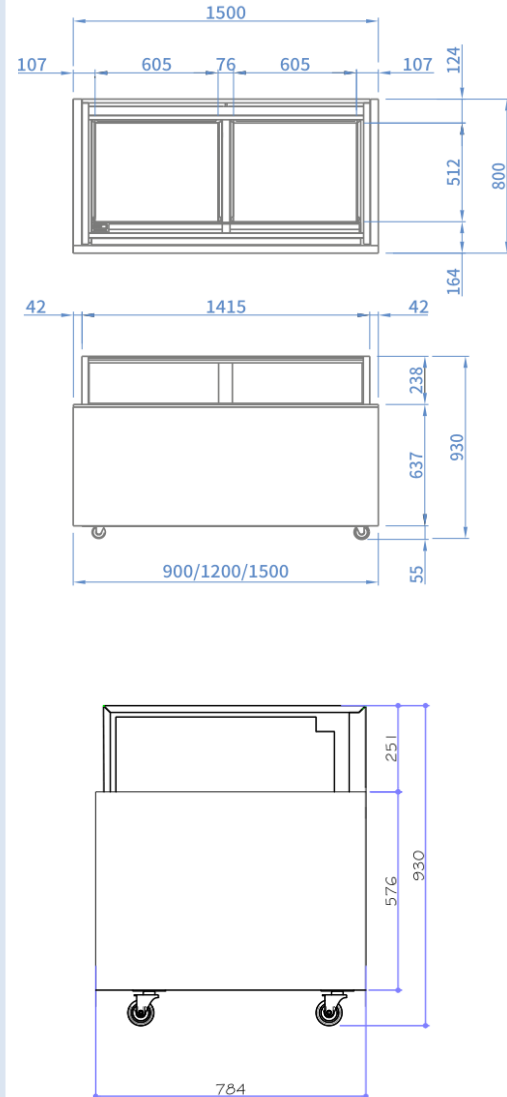

WARRANTY 2 YEARS
PARTS & LABOUR



■ ADD: 218 WOODPARK ROAD SMITHFIELD NSW 2164
■ TEL: 02 - 8798 - 5061 / 5283 / 5581
■ FAX: 02 - 8798 - 5707